

TECHNICAL SPECIFICATIONS

1) DESIGN CONDITIONS

- 1.1 BASIC WIND SPEED : 35 m/s (BS 5649) SUPERSEDED BY BS EN 40-3-1
- 1.2 10 MINUTES MEAN WIND VELOCITY : 20.6 m/s (BS EN 40-3-1) EQUIVALENT TO BS 5649 3-SEC GUST BASIC WIND SPEED OF 35 m/s

- 1.3 TOTAL LUMINAIRES SAIL AREA : 0.52 m² Δ
- 1.4 TOTAL WEIGHT OF LUMINAIRES : 52 KG Δ

2) STANDARDS

- 2.1 POLE DESIGN : BS EN 40-3-1 & BS EN 40-3-3
- 2.2 MATERIAL : BS EN 10025 S275JR
- 2.3 WELDING (ELECTRIC ARC WELDING) : BS EN 1011-2
- 2.4 GALVANIZING : BS EN ISO 1461 / BS 729

3) TESTING PROCEDURES

- : DIMENSIONAL VERIFICATION, GALVANIZING THICKNESS, MATERIAL STRENGTH & THICKNESS TYPE TEST: BS EN 40-3-2

4) QUALITY CONTROL PROCEDURES

- : THE SUPPLIER / MANUFACTURER AND GALVANIZER SHALL BE ISO 9001 : 2015 ACCREDITED

MANUFACTURER'S COMPLIANCE

- 1) LOCALLY MANUFACTURED PRODUCTS : -MANUFACTURER'S DECLARATION THAT POLE SECTIONS AND COMPONENTS ARE "MADE IN MALAYSIA" IN COMPLIANCE TO MOF "SURAT PEKELILING PERBENDAHARAAN BIL.7 TAHUN 2002".
-HOT ROLLED STEEL COIL WITH LOCAL STEEL MILL CERTIFICATES.
- 2) MANUFACTURING AND HOT DIP GALVANIZING : -PREFERED IN-HOUSE MANUFACTURING WITH HOT DIP GALVANIZING PROCESSES.
- 3) PROVIDE COMPULSORY TESTING AT MANUFACTURER'S FACTORY : -TYPE TEST TO BS EN 40-3-2
-GALVANIZING TEST
-MATERIAL TEST
-WELDING TEST BY DYE PENETRANT
- 4) CERTIFICATION : -JKR / ISO / SIRIM
- 5) REGISTRATION : -MITI / IKRAM / MOF / CIDB
- 6) TRACK RECORD : -EVIDENCE OF MIN. 10 YEARS MANUFACTURING & SUPPLY TRACK RECORDS.
- 7) PE ENDORSEMENT : -PE ENDORSEMENT MANDATORY FOR ALL POLE DESIGN CALCULATIONS & DRAWINGS FOR SUBMISSION.
- 8) DESIGN CALCULATION : -DESIGN CALCULATIONS INCORPORATING UNFACTORED GROUND REACTIONS SHALL BE VALIDATED, REVIEWED AND APPROVED.

* UTILITY INNOVATION APPLICATION NO : UI 2012001805

CUSTOMER APPROVED DRAWING
FOR MANUFACTURE

(Co. stamp, sign & date)

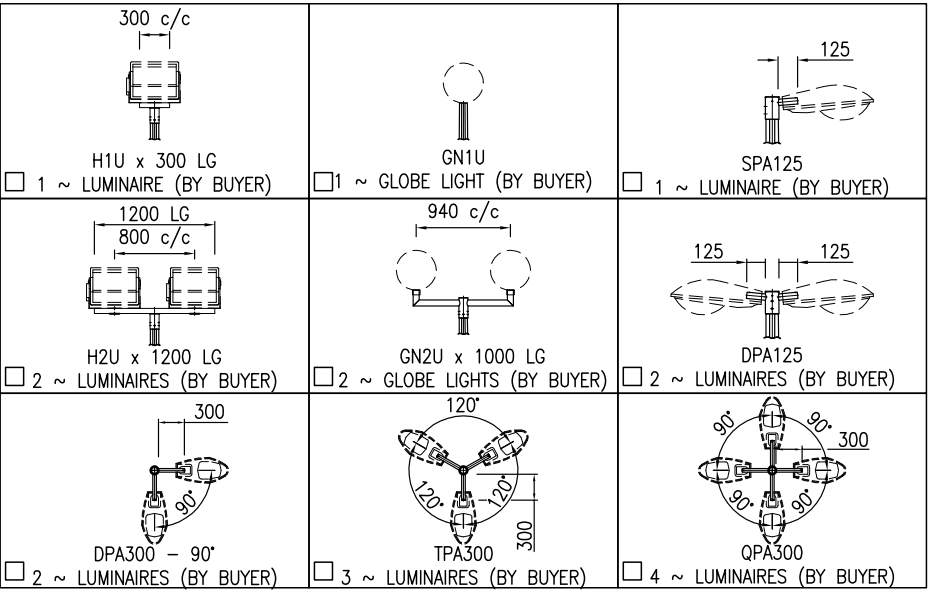
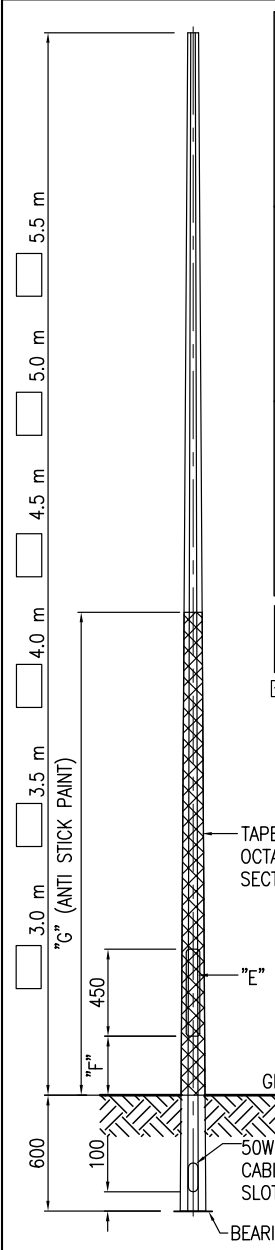

* NOTE : UNLESS SPECIFIED BY CUSTOMER, STANDARD LUMINAIRE MOUNTING HOLE IS 18 ϕ
 TICK WHERE APPLICABLE

- "E" DOOR TYPE** Δ
- STEEL
- FIBRE WITH _____ WORDING
- "F" DOOR FROM GROUND**
- 500 mm
- _____ mm
- "G" ANTI STICK PAINT**
- FROM GROUND**
- 2.5 m
- _____ m
- NOT REQUIRED

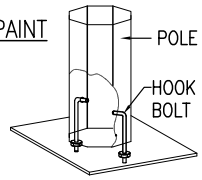

**ISOMETRIC VIEW
BASE SECTION**

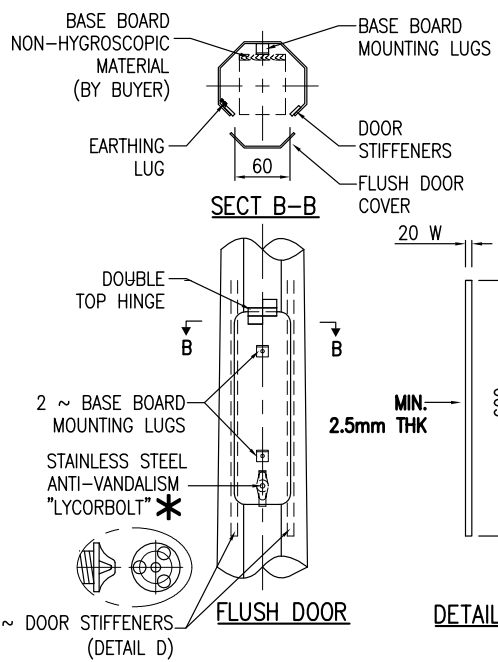

2 ~ DOOR STIFFENERS (DETAIL D)

TILT "θ"	
0°	<input type="checkbox"/>
5°	<input type="checkbox"/>
10°	<input type="checkbox"/>
15°	<input type="checkbox"/>



DETAIL D

REV	DETAILS	BY	CHD	DATE
C	AS NOTED ABOVE	TUNG	LSK	13.12.18
B	WARRANTY	THOO	LSK	13.06.18
A	WARRANTY	THOO	LSK	01.08.16

© LMSB, All Rights Reserved. This printout is copyright and shall not be reproduced without written permission from Lysaght Marketing Sdn Bhd. The Company reserves the right to make alterations to design without notice.

PRELIMINARY DRAWING FOR TENDER PURPOSES ONLY

 PROJECTION
 ALL DIMS ARE SUBJECT TO MANUFACTURING TOLERANCES

CLIENT :
 PROJECT :
 DRAWN : SHA CHD : *Shah Chuan* DATE: 10.01.12
LYSAGHT MARKETING SDN BHD
 CO. NO.: 102382-M

TITLE : **3m ~ 5.5m VERTICAL LIGHTING COLUMN (PLANTED TYPE)**
 SCALE : 1 : 35 SHEET 1 of 2 REV A B C
 This drawing and the information contained herein is the sole property of LYSAGHT MARKETING SDN BHD, is strictly confidential and must not be used or disclosed without the written consent of LYSAGHT MARKETING SDN BHD. CO. NO.: 102382-M

DWG./REF. NO. **V030PA ~ V055PA**
 DIMENSIONS IN mm UNLESS STATED
 SHEET SIZE **A4**

TECHNICAL SPECIFICATIONS

- 1) DESIGN CONDITIONS
 - 1.1 BASIC WIND SPEED : 35 m/s (BS 5649) SUPERSEDED BY BS EN 40-3-1
 - 1.2 10 MINUTES MEAN WIND VELOCITY : 20.6 m/s (BS EN 40-3-1) EQUIVALENT TO BS 5649 3-SEC GUST BASIC WIND SPEED OF 35 m/s
 - 1.3 TOTAL LUMINAIRES SAIL AREA : 0.52 m²
 - 1.4 TOTAL WEIGHT OF LUMINAIRES : 52 KG
- 2) STANDARDS
 - 2.1 POLE DESIGN : BS EN 40-3-1 & BS EN 40-3-3 EN 12767 CLASS 0
 - 2.2 MATERIAL : BS EN 10025 S275JR
 - 2.3 WELDING (ELECTRIC ARC WELDING) : BS EN 1011-2
 - 2.4 GALVANIZING : BS EN ISO 1461 / BS 729
- 3) TESTING PROCEDURES : DIMENSIONAL VERIFICATION, GALVANIZING THICKNESS, MATERIAL STRENGTH & THICKNESS TYPE TEST: BS EN 40-3-2
- 4) QUALITY CONTROL PROCEDURES : THE SUPPLIER / MANUFACTURER AND GALVANIZER SHALL BE ISO 9001 : 2015 ACCREDITED

MANUFACTURER'S COMPLIANCE

- 1) LOCALLY MANUFACTURED PRODUCTS : -MANUFACTURER'S DECLARATION THAT POLE SECTIONS AND COMPONENTS ARE "MADE IN MALAYSIA" IN COMPLIANCE TO MOF "SURAT PEKELILING PERBENDAHARAAN BIL.7 TAHUN 2002".
-HOT ROLLED STEEL COIL WITH LOCAL STEEL MILL CERTIFICATES.
- 2) MANUFACTURING AND HOT DIP GALVANIZING : -PREFERRED IN-HOUSE MANUFACTURING WITH HOT DIP GALVANIZING PROCESSES.
- 3) PROVIDE COMPULSORY TESTING AT MANUFACTURER'S FACTORY : -TYPE TEST TO BS EN 40-3-2
-GALVANIZING TEST
-MATERIAL TEST
-WELDING TEST BY DYE PENETRANT
- 4) CERTIFICATION : -JKR / ISO / SIRIM
- 5) REGISTRATION : -MITI / IKRAM / MOF / CIDB
- 6) TRACK RECORD : -EVIDENCE OF MIN. 10 YEARS MANUFACTURING & SUPPLY TRACK RECORDS.
- 7) PE ENDORSEMENT : -PE ENDORSEMENT MANDATORY FOR ALL POLE DESIGN CALCULATIONS & DRAWINGS FOR SUBMISSION.
- 8) DESIGN CALCULATION : -DESIGN CALCULATIONS INCORPORATING UNFACTORED GROUND REACTIONS SHALL BE VALIDATED, REVIEWED AND APPROVED.

* UTILITY INNOVATION APPLICATION NO : UI 2012001805

CUSTOMER APPROVED DRAWING
FOR MANUFACTURE

(Co. stamp, sign & date)

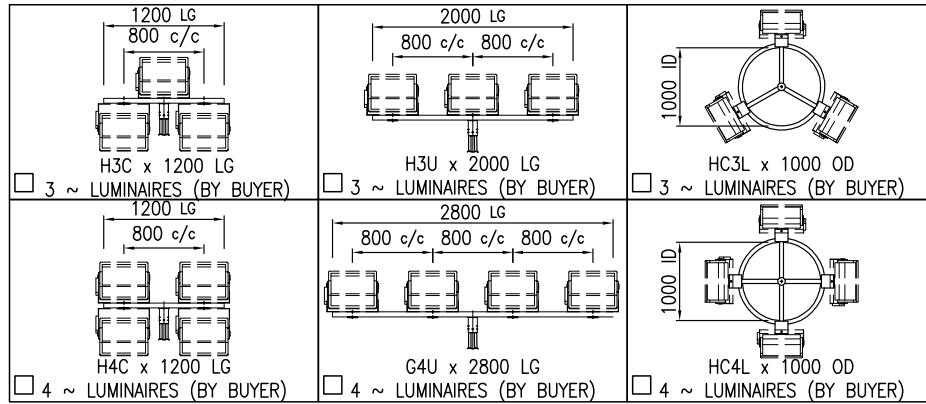

* NOTE : UNLESS SPECIFIED BY CUSTOMER, STANDARD LUMINAIRE MOUNTING HOLE IS 18φ

TICK WHERE APPLICABLE

"E" DOOR TYPE

- STEEL
- FIBRE WITH _____ WORDING

"F" DOOR FROM GROUND

- 500 mm
- _____ mm

"G" ANTI STICK PAINT FROM GROUND

- 2.5 m
- _____ m
- NOT REQUIRED

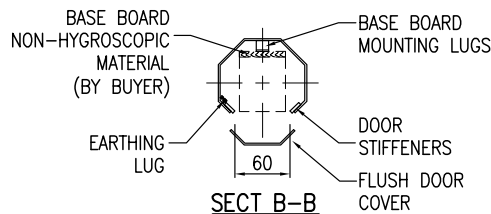

SECT B-B

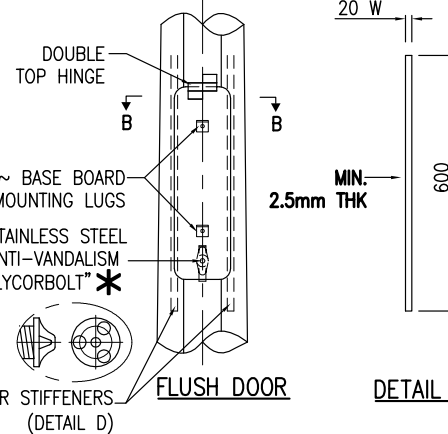

DETAIL D

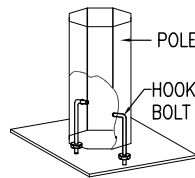

ISOMETRIC VIEW BASE SECTION

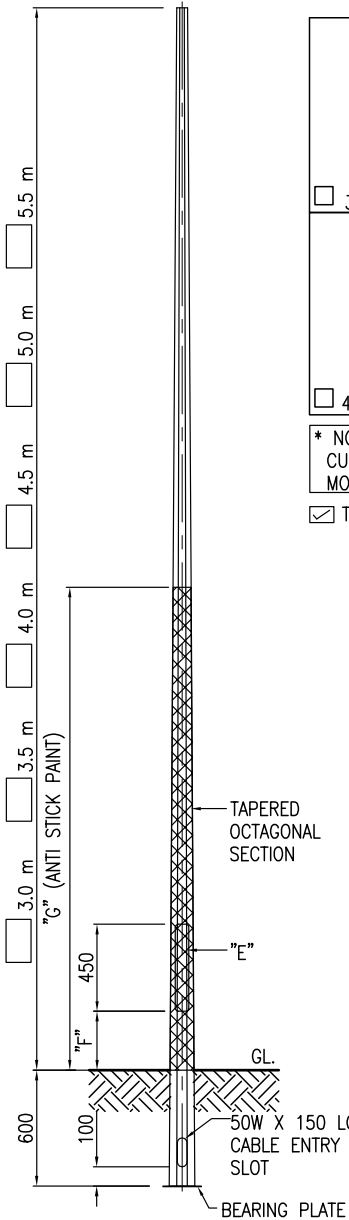

© LMSB, All Rights Reserved. This printout is copyright and shall not be reproduced without written permission from Lysaght Marketing Sdn Bhd. The Company reserves the right to make alterations to design without notice.	PRELIMINARY DRAWING FOR TENDER PURPOSES ONLY	CLIENT :	TITLE : 3m ~ 5.5m VERTICAL LIGHTING COLUMN (PLANTED TYPE)	DWG./REF. NO. V030PA ~ V055PA
C AS NOTED ABOVE	TUNG LSK 13.12.18	PROJECT:	SCALE : 1 : 35	SHEET 2 of 2
B WARRANTY	THOO LSK 13.06.18	DRAWN : SHA	CHD	DATE: 10.01.12
A WARRANTY	THOO LSK 01.08.16	LYSAGHT MARKETING SDN BHD		
REV DETAILS	BY CHD	DATE	CO. NO.: 102382-M	

PROJECTION	ALL DIMS ARE SUBJECT TO MANUFACTURING TOLERANCES
------------	--

CLIENT :	TITLE : 3m ~ 5.5m VERTICAL LIGHTING COLUMN (PLANTED TYPE)
PROJECT:	DWG./REF. NO. V030PA ~ V055PA
DRAWN : SHA	SCALE : 1 : 35
CHD	SHEET 2 of 2
DATE: 10.01.12	REV A B C

LYSAGHT MARKETING SDN BHD		This drawing and the information contained herein is the sole property of LYSAGHT MARKETING SDN BHD, is strictly confidential and must not be used or disclosed without the written consent of LYSAGHT MARKETING SDN BHD. CO. NO.: 102382-M	
CO. NO.: 102382-M		DIMENSIONS IN mm UNLESS STATED	SHEET SIZE A4

DIMENSIONS IN mm UNLESS STATED		SHEET SIZE A4
--------------------------------	--	---------------