

TECHNICAL SPECIFICATIONS

- 1) DESIGN CONDITIONS
- 1.1 BASIC WIND SPEED : 35 m/s (BS 5649) SUPERSEDED BY BS EN 40-3-1
 - 1.2 10 MINUTES MEAN WIND VELOCITY : 20.6 m/s (BS EN 40-3-1) EQUIVALENT TO BS 5649 3-SEC GUST BASIC WIND SPEED OF 35 m/s
 - 1.3 TOTAL LUMINAIRES SAIL AREA : 0.5 m²
 - 1.4 TOTAL WEIGHT OF LUMINAIRES : 50 KG D
- 2) STANDARDS
- 2.1 POLE DESIGN : BS EN 40-3-1 & BS EN 40-3-3 EN 12767 CLASS 0
 - 2.2 MATERIAL : BS EN 10025 S275JR
 - 2.3 WELDING (ELECTRIC ARC WELDING) : BS EN 1011-2
 - 2.4 GALVANIZING : BS EN ISO 1461 / BS 729
- 3) TESTING PROCEDURES : DIMENSIONAL VERIFICATION, GALVANIZING THICKNESS, MATERIAL STRENGTH & THICKNESS TYPE TEST: BS EN 40-3-2
- 4) QUALITY CONTROL PROCEDURES : THE SUPPLIER / MANUFACTURER AND GALVANIZER SHALL BE ISO 9001 : 2015 ACCREDITED

MANUFACTURER'S COMPLIANCE

- 1) LOCALLY MANUFACTURED PRODUCTS : -MANUFACTURER'S DECLARATION THAT POLE SECTIONS AND COMPONENTS ARE "MADE IN MALAYSIA" IN COMPLIANCE TO MOF "SURAT PEKELILING PERBENDAHARAAN BIL.7 TAHUN 2002".
 -HOT ROLLED STEEL COIL WITH LOCAL STEEL MILL CERTIFICATES.
- 2) MANUFACTURING AND HOT DIP GALVANIZING : -PREFERRED IN-HOUSE MANUFACTURING WITH HOT DIP GALVANIZING PROCESSES.
- 3) PROVIDE COMPULSORY TESTING AT MANUFACTURER'S FACTORY : -TYPE TEST TO BS EN 40-3-2
 -GALVANIZING TEST
 -MATERIAL TEST
 -WELDING TEST BY DYE PENETRANT
- 4) CERTIFICATION : -JKR / ISO / SIRIM
- 5) REGISTRATION : -MITI / IKRAM / MOF / CIDB
- 6) TRACK RECORD : -EVIDENCE OF MIN. 10 YEARS MANUFACTURING & SUPPLY TRACK RECORDS.
- 7) PE ENDORSEMENT : -PE ENDORSEMENT MANDATORY FOR ALL POLE DESIGN CALCULATIONS & DRAWINGS FOR SUBMISSION.
- 8) DESIGN CALCULATION : -DESIGN CALCULATIONS INCORPORATING UNFACTORED GROUND REACTIONS SHALL BE VALIDATED, REVIEWED AND APPROVED.

* UTILITY INNOVATION APPLICATION NO : UI 2012001805

CUSTOMER APPROVED DRAWING
FOR MANUFACTURE

(Co. stamp, sign & date)

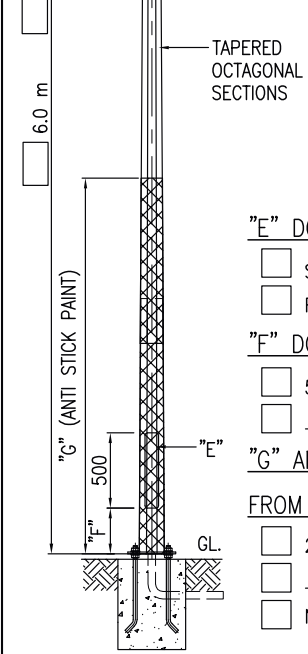
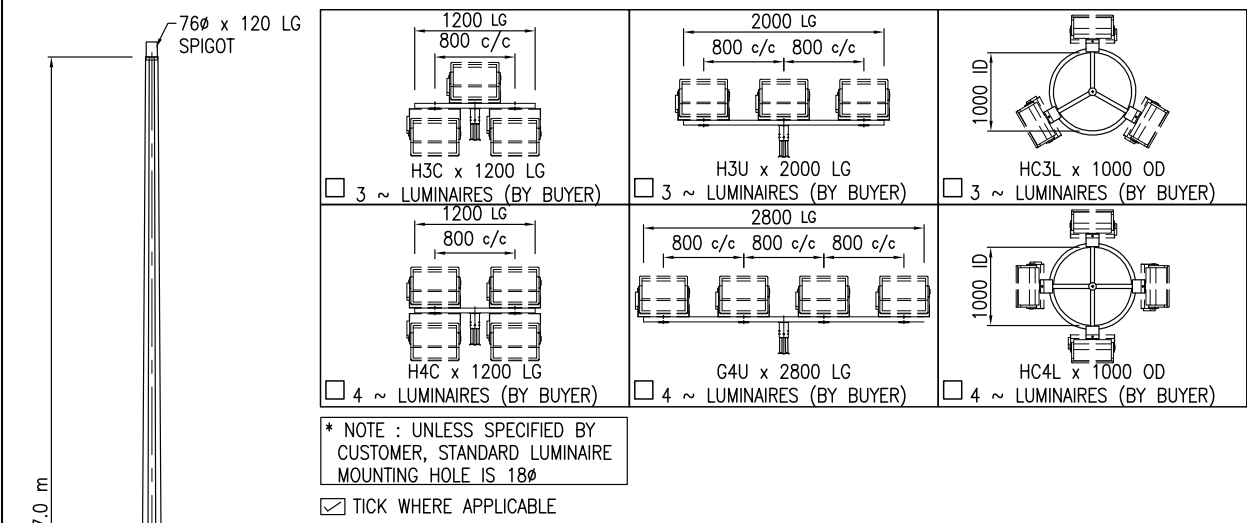

- "E" DOOR TYPE D
- STEEL
 - FIBRE WITH _____ WORDING
- "F" DOOR FROM GROUND
- 500 mm
 - _____ mm
- "G" ANTI STICK PAINT FROM GROUND
- 2.5 m
 - _____ m
 - NOT REQUIRED

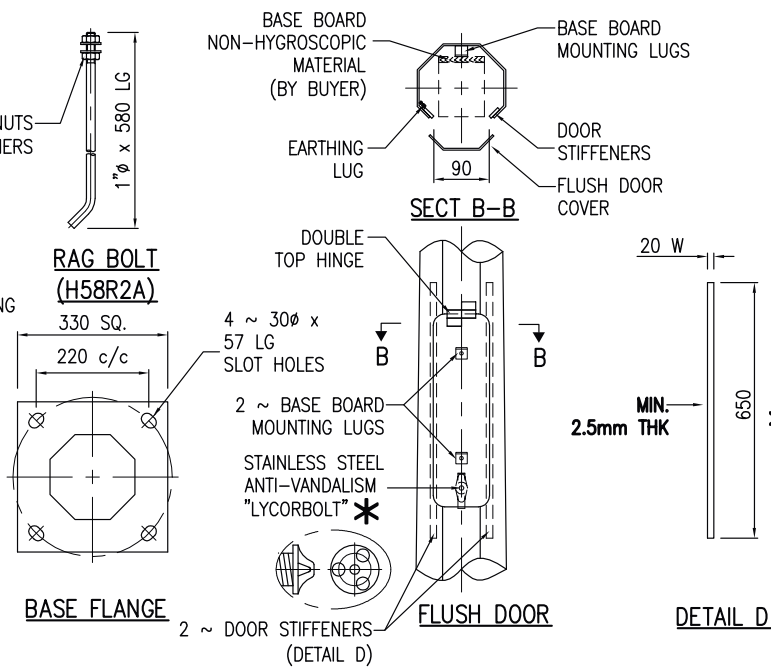

D	AS NOTED ABOVE	TUNG	LSK	12.12.18	© LMSB, All Rights Reserved. This printout is copyright and shall not be reproduced without written permission from Lysaght Marketing Sdn Bhd. The Company reserves the right to make alterations to design without notice.	PRELIMINARY DRAWING FOR TENDER PURPOSES ONLY PROJECTION ALL DIMS ARE SUBJECT TO MANUFACTURING TOLERANCES	CLIENT :	TITLE : 6m ~ 7m VERTICAL LIGHTING COLUMN (FLANGED V-TYPE)	DWG./REF. NO.	
C	WARRANTY	THOO	LSK	13.06.18		DRAWN : <i>SHA</i> CHD: <i>Chin Chuan</i> DATE: 10.01.12	PROJECT:	SCALE : 1 : 45	SHEET 2 of 2	REV A B C D
B	WARRANTY	THOO	LSK	01.08.16			LYSAGHT MARKETING SDN BHD CO. NO.: 102382-M	This drawing and the information contained herein is the sole property of LYSAGHT MARKETING SDN BHD, is strictly confidential and must not be used or disclosed without the written consent of LYSAGHT MARKETING SDN BHD. CO. NO.: 102382-M	DIMENSIONS IN mm UNLESS STATED	SHEET SIZE A4
A	TYPE OF POLE	SOON	LSK	13.06.16						
REV	DETAILS	BY	CHD	DATE						

TECHNICAL SPECIFICATIONS

- 1) DESIGN CONDITIONS
- 1.1 BASIC WIND SPEED : 35 m/s (BS 5649) SUPERSEDED BY BS EN 40-3-1
 - 1.2 10 MINUTES MEAN WIND VELOCITY : 20.6 m/s (BS EN 40-3-1) EQUIVALENT TO BS 5649 3-SEC GUST BASIC WIND SPEED OF 35 m/s
 - 1.3 TOTAL LUMINAIRES SAIL AREA : 0.50 m²
 - 1.4 TOTAL WEIGHT OF LUMINAIRES : 50 KG 
- 2) STANDARDS
- 2.1 POLE DESIGN : BS EN 40-3-1 & BS EN 40-3-3 EN 12767 CLASS 0 BS EN 10025 S275JR
 - 2.2 MATERIAL : BS EN 1011-2
 - 2.3 WELDING (ELECTRIC ARC WELDING) : BS EN ISO 1461 / BS 729
 - 2.4 GALVANIZING : DIMENSIONAL VERIFICATION, GALVANIZING THICKNESS, MATERIAL STRENGTH & THICKNESS TYPE TEST: BS EN 40-3-2
- 3) TESTING PROCEDURES : THE SUPPLIER / MANUFACTURER AND GALVANIZER SHALL BE ISO 9001 : 2015 ACCREDITED
- 4) QUALITY CONTROL PROCEDURES

MANUFACTURER'S COMPLIANCE

- 1) LOCALLY MANUFACTURED PRODUCTS : -MANUFACTURER'S DECLARATION THAT POLE SECTIONS AND COMPONENTS ARE "MADE IN MALAYSIA" IN COMPLIANCE TO MOF "SURAT PEKELILING PERBENDAHARAAN BIL.7 TAHUN 2002".
-HOT ROLLED STEEL COIL WITH LOCAL STEEL MILL CERTIFICATES.
- 2) MANUFACTURING AND HOT DIP GALVANIZING : -PREFERRED IN-HOUSE MANUFACTURING WITH HOT DIP GALVANIZING PROCESSES.
- 3) PROVIDE COMPULSORY TESTING AT MANUFACTURER'S FACTORY : -TYPE TEST TO BS EN 40-3-2
-GALVANIZING TEST
-MATERIAL TEST
-WELDING TEST BY DYE PENETRANT
- 4) CERTIFICATION : -JKR / ISO / SIRIM
- 5) REGISTRATION : -MITI / IKRAM / MOF / CIDB
- 6) TRACK RECORD : -EVIDENCE OF MIN. 10 YEARS MANUFACTURING & SUPPLY TRACK RECORDS.
- 7) PE ENDORSEMENT : -PE ENDORSEMENT MANDATORY FOR ALL POLE DESIGN CALCULATIONS & DRAWINGS FOR SUBMISSION.
- 8) DESIGN CALCULATION : -DESIGN CALCULATIONS INCORPORATING UNFACTORED GROUND REACTIONS SHALL BE VALIDATED, REVIEWED AND APPROVED.

* UTILITY INNOVATION APPLICATION NO : UI 2012001805

CUSTOMER APPROVED DRAWING FOR MANUFACTURE

(Co. stamp, sign & date)

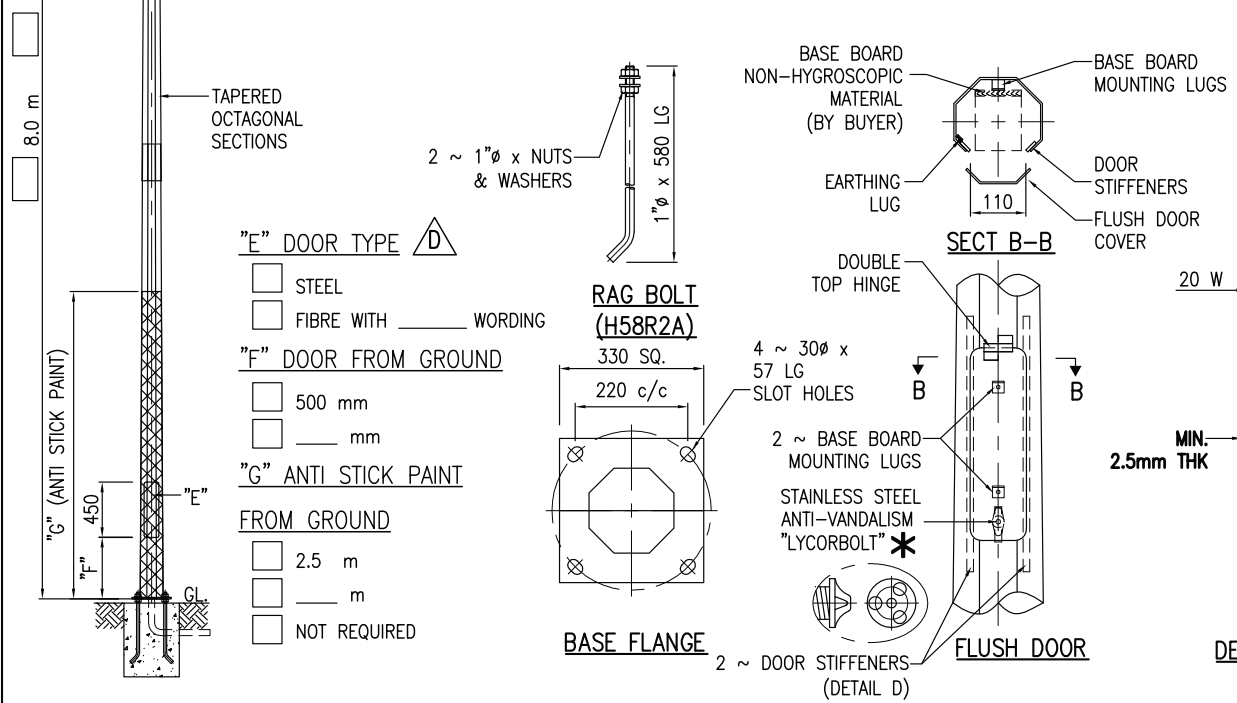
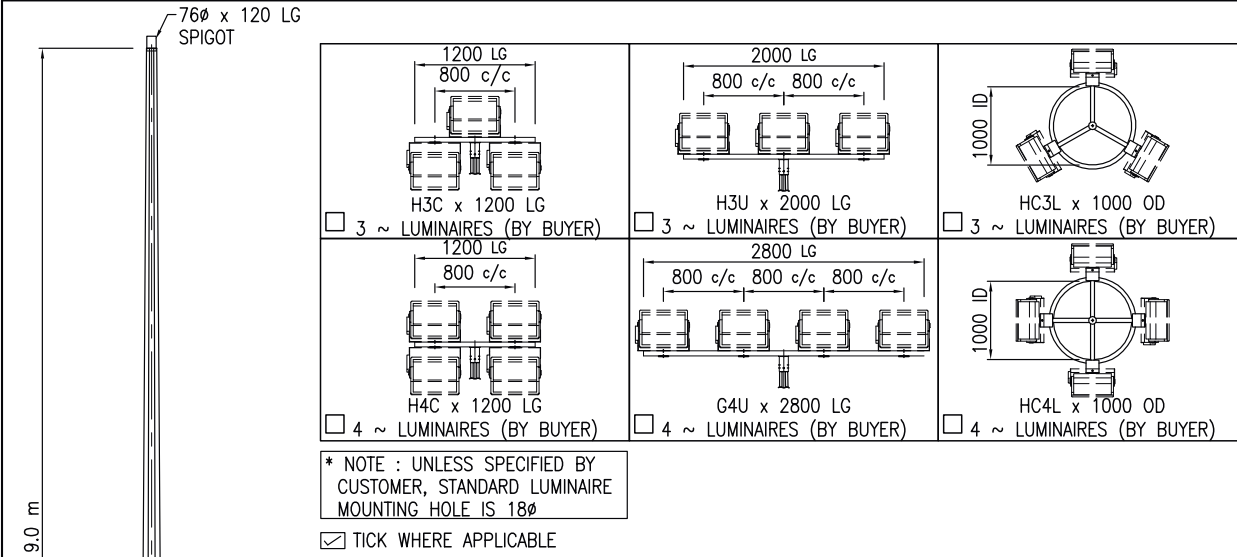

D	AS NOTED ABOVE	TUNG	LSK	12.12.18	© LMSB, All Rights Reserved. This printout is copyright and shall not be reproduced without written permission from Lysaght Marketing Sdn Bhd. The Company reserves the right to make alterations to design without notice.	PRELIMINARY DRAWING FOR TENDER PURPOSES ONLY	CLIENT :	TITLE : 8m ~ 9m VERTICAL LIGHTING COLUMN (FLANGED V-TYPE)	DWG./REF. NO.	
C	WARRANTY	TH00	LSK	13.06.18			PROJECT:	SCALE : 1 : 55	SHEET 2 of 3	
B	WARRANTY	TH00	LSK	01.08.16			DRAWN : SHA	CHD: <i>Chuan Chuan</i>	DATE: 10.01.12	
A	TYPE OF POLE	SOON	LSK	13.06.16			LYSAGHT MARKETING SDN BHD CO. NO.: 102382-M			This drawing and the information contained herein is the sole property of LYSAGHT MARKETING SDN BHD, is strictly confidential and must not be used or disclosed without the written consent of LYSAGHT MARKETING SDN BHD. CO. NO.: 102382-M
REV	DETAILS	BY	CHD	DATE		ALL DIMS ARE SUBJECT TO MANUFACTURING TOLERANCES				DIMENSIONS IN mm UNLESS STATED SHEET SIZE A4

TECHNICAL SPECIFICATIONS

- 1) DESIGN CONDITIONS
- 1.1 BASIC WIND SPEED : 35 m/s (BS 5649) SUPERSEDED BY BS EN 40-3-1
 - 1.2 10 MINUTES MEAN WIND VELOCITY : 20.6 m/s (BS EN 40-3-1) EQUIVALENT TO BS 5649 3-SEC GUST BASIC WIND SPEED OF 35 m/s
 - 1.3 TOTAL LUMINAIRES SAIL AREA : 0.5 m²
 - 1.4 TOTAL WEIGHT OF LUMINAIRES : 50 KG
- 2) STANDARDS
- 2.1 POLE DESIGN : BS EN 40-3-1 & BS EN 40-3-3 EN 12767 CLASS 0 BS EN 10025 S275JR
 - 2.2 MATERIAL : BS EN 1011-2
 - 2.3 WELDING (ELECTRIC ARC WELDING) : BS EN ISO 1461 / BS 729
 - 2.4 GALVANIZING
- 3) TESTING PROCEDURES : DIMENSIONAL VERIFICATION, GALVANIZING THICKNESS, MATERIAL STRENGTH & THICKNESS TYPE TEST: BS EN 40-3-2
- 4) QUALITY CONTROL PROCEDURES : THE SUPPLIER / MANUFACTURER AND GALVANIZER SHALL BE ISO 9001 : 2015 ACCREDITED

MANUFACTURER'S COMPLIANCE

- 1) LOCALLY MANUFACTURED PRODUCTS : -MANUFACTURER'S DECLARATION THAT POLE SECTIONS AND COMPONENTS ARE "MADE IN MALAYSIA" IN COMPLIANCE TO MOF "SURAT PEKELILING PERBENDAHARAAN BIL.7 TAHUN 2002".
-HOT ROLLED STEEL COIL WITH LOCAL STEEL MILL CERTIFICATES.
- 2) MANUFACTURING AND HOT DIP GALVANIZING : -PREFERRED IN-HOUSE MANUFACTURING WITH HOT DIP GALVANIZING PROCESSES.
- 3) PROVIDE COMPULSORY TESTING AT MANUFACTURER'S FACTORY : -TYPE TEST TO BS EN 40-3-2
-GALVANIZING TEST
-MATERIAL TEST
-WELDING TEST BY DYE PENETRANT
- 4) CERTIFICATION : -JKR / ISO / SIRIM
- 5) REGISTRATION : -MITI / IKRAM / MOF / CIDB
- 6) TRACK RECORD : -EVIDENCE OF MIN. 10 YEARS MANUFACTURING & SUPPLY TRACK RECORDS.
- 7) PE ENDORSEMENT : -PE ENDORSEMENT MANDATORY FOR ALL POLE DESIGN CALCULATIONS & DRAWINGS FOR SUBMISSION.
- 8) DESIGN CALCULATION : -DESIGN CALCULATIONS INCORPORATING UNFACTORED GROUND REACTIONS SHALL BE VALIDATED, REVIEWED AND APPROVED.

* UTILITY INNOVATION APPLICATION NO : UI 2012001805

CUSTOMER APPROVED DRAWING
FOR MANUFACTURE

(Co. stamp, sign & date)

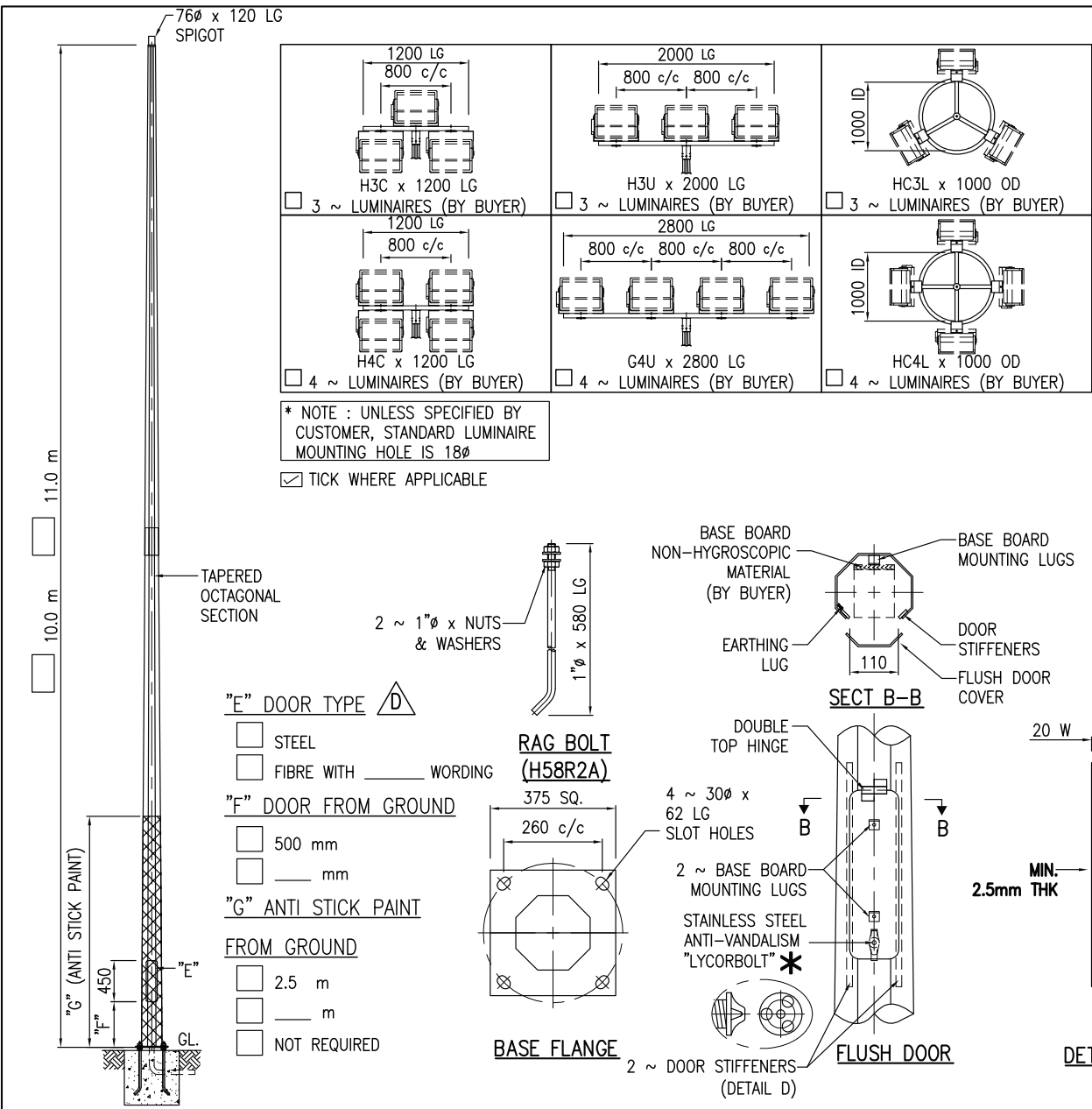

- "E" DOOR TYPE
- STEEL
 - FIBRE WITH _____ WORDING
- "F" DOOR FROM GROUND
- 500 mm
 - _____ mm
- "G" ANTI STICK PAINT FROM GROUND
- 2.5 m
 - _____ m
 - NOT REQUIRED

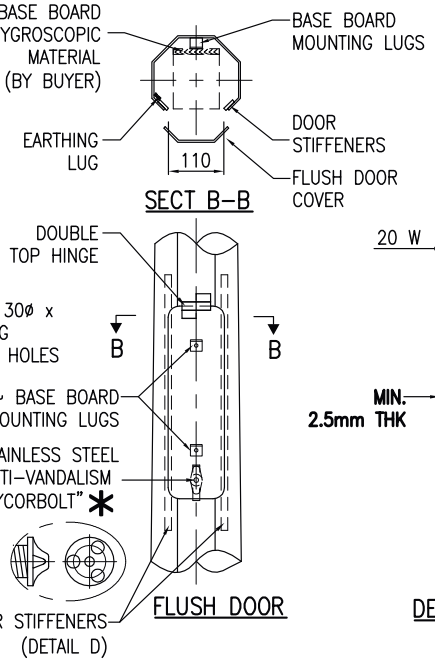
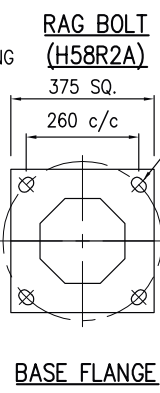

D	AS NOTED ABOVE	TUNG	LSK	12.12.18	© LMSB, All Rights Reserved. This printout is copyright and shall not be reproduced without written permission from Lysaght Marketing Sdn Bhd. The Company reserves the right to make alterations to design without notice.	PRELIMINARY DRAWING FOR TENDER PURPOSES ONLY PROJECTION ALL DIMS ARE SUBJECT TO MANUFACTURING TOLERANCES	CLIENT :	TITLE : 10m ~ 11m VERTICAL LIGHTING COLUMN (FLANGED V-TYPE)	DWG./REF. NO.
C	WARRANTY	TH00	LSK	13.06.18			PROJECT:		V100FA ~ V110FA
B	WARRANTY	TH00	LSK	01.08.16			DRAWN : SHA	CHD: <i>Chuan Shun Han</i>	DATE: 10.01.12
A	TYPE OF POLE	SOON	LSK	13.06.16			SCALE : 1 : 65	SHEET 2 of 3	REV A B C D
REV	DETAILS	BY	CHD	DATE			LYSAGHT MARKETING SDN BHD CO. NO.: 102382-M		This drawing and the information contained herein is the sole property of LYSAGHT MARKETING SDN BHD, is strictly confidential and must not be used or disclosed without the written consent of LYSAGHT MARKETING SDN BHD. CO. NO.: 102382-M

TECHNICAL SPECIFICATIONS

- 1) DESIGN CONDITIONS
- 1.1 BASIC WIND SPEED : 35 m/s (BS 5649) SUPERSEDED BY BS EN 40-3-1
 - 1.2 10 MINUTES MEAN WIND VELOCITY : 20.6 m/s (BS EN 40-3-1) EQUIVALENT TO BS 5649 3-SEC GUST BASIC WIND SPEED OF 35 m/s
 - 1.3 TOTAL LUMINAIRES SAIL AREA : 0.5 m²
 - 1.4 TOTAL WEIGHT OF LUMINAIRES : 50 KG 
- 2) STANDARDS
- 2.1 POLE DESIGN : BS EN 40-3-1 & BS EN 40-3-3 EN 12767 CLASS 0 BS EN 10025 S275JR
 - 2.2 MATERIAL : BS EN 1011-2
 - 2.3 WELDING (ELECTRIC ARC WELDING) : BS EN ISO 1461 / BS 729
 - 2.4 GALVANIZING : DIMENSIONAL VERIFICATION, GALVANIZING THICKNESS, MATERIAL STRENGTH & THICKNESS TYPE TEST: BS EN 40-3-2
- 3) TESTING PROCEDURES : THE SUPPLIER / MANUFACTURER AND GALVANIZER SHALL BE ISO 9001 : 2015 ACCREDITED
- 4) QUALITY CONTROL PROCEDURES

MANUFACTURER'S COMPLIANCE

- 1) LOCALLY MANUFACTURED PRODUCTS : -MANUFACTURER'S DECLARATION THAT POLE SECTIONS AND COMPONENTS ARE "MADE IN MALAYSIA" IN COMPLIANCE TO MOF "SURAT PEKELILING PERBENDAHARAAN BIL.7 TAHUN 2002".
-HOT ROLLED STEEL COIL WITH LOCAL STEEL MILL CERTIFICATES.
- 2) MANUFACTURING AND HOT DIP GALVANIZING : -PREFERRED IN-HOUSE MANUFACTURING WITH HOT DIP GALVANIZING PROCESSES.
- 3) PROVIDE COMPULSORY TESTING AT MANUFACTURER'S FACTORY : -TYPE TEST TO BS EN 40-3-2
-GALVANIZING TEST
-MATERIAL TEST
-WELDING TEST BY DYE PENETRANT
- 4) CERTIFICATION : -JKR / ISO / SIRIM
- 5) REGISTRATION : -MITI / IKRAM / MOF / CIDB
- 6) TRACK RECORD : -EVIDENCE OF MIN. 10 YEARS MANUFACTURING & SUPPLY TRACK RECORDS.
- 7) PE ENDORSEMENT : -PE ENDORSEMENT MANDATORY FOR ALL POLE DESIGN CALCULATIONS & DRAWINGS FOR SUBMISSION.
- 8) DESIGN CALCULATION : -DESIGN CALCULATIONS INCORPORATING UNFACTORED GROUND REACTIONS SHALL BE VALIDATED, REVIEWED AND APPROVED.

* UTILITY INNOVATION APPLICATION NO : UI 2012001805

CUSTOMER APPROVED DRAWING FOR MANUFACTURE

(Co. stamp, sign & date)

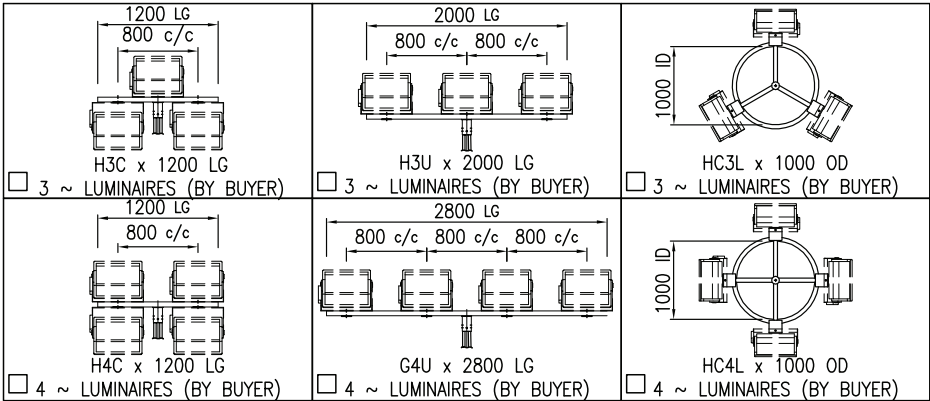
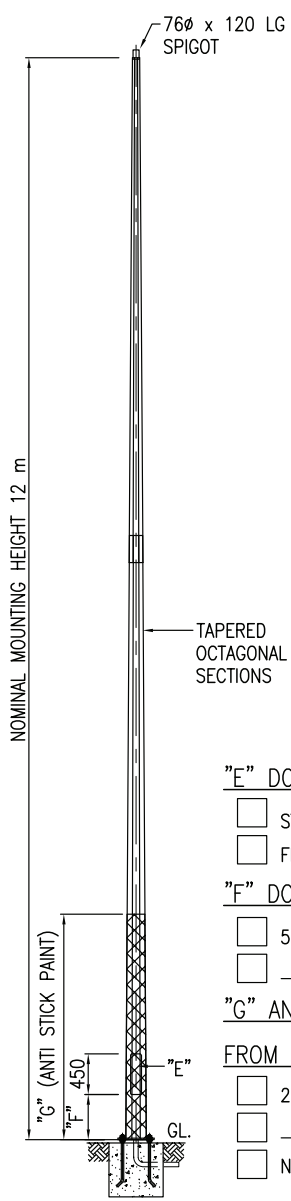

* NOTE : UNLESS SPECIFIED BY CUSTOMER, STANDARD LUMINAIRE MOUNTING HOLE IS 18φ

TICK WHERE APPLICABLE

- "E" DOOR TYPE 
- STEEL
 - FIBRE WITH _____ WORDING
- "F" DOOR FROM GROUND
- 500 mm
 - _____ mm
- "G" ANTI STICK PAINT FROM GROUND
- 2.5 m
 - _____ m
 - NOT REQUIRED

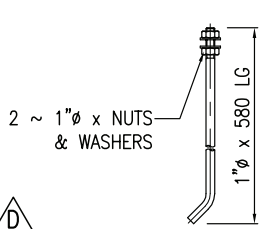

RAG BOLT (H58R2A) 400 SQ.

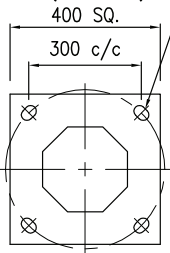

BASE FLANGE

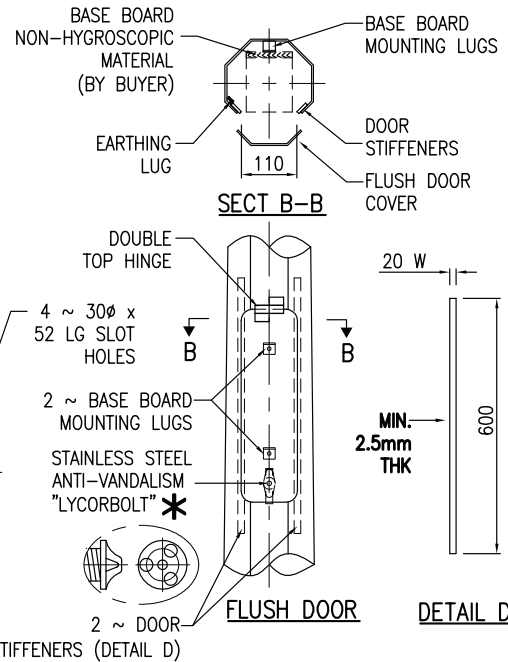

D	AS NOTED ABOVE	TUNG	LSK	12.12.18	© LMSB, All Rights Reserved. This printout is copyright and shall not be reproduced without written permission from Lysaght Marketing Sdn Bhd. The Company reserves the right to make alterations to design without notice.	PRELIMINARY DRAWING FOR TENDER PURPOSES ONLY  PROJECTION ALL DIMS ARE SUBJECT TO MANUFACTURING TOLERANCES	CLIENT :	TITLE : 12m VERTICAL LIGHTING COLUMN (FLANGED V-TYPE)				DWG./REF. NO.			
C	WARRANTY	THOO	LSK	13.06.18			PROJECT:					V120FA			
B	WARRANTY	THOO	LSK	01.08.16			DRAWN : SHA	CHD: <i>Chuan Chuan</i>	DATE: 10.01.12	SCALE : 1 : 75	SHEET 2 of 3	REV A B C D			
A	TYPE OF POLE	SOON	LSK	13.06.16			 LYSAGHT MARKETING SDN BHD CO. NO.: 102382-M			This drawing and the information contained herein is the sole property of LYSAGHT MARKETING SDN BHD, is strictly confidential and must not be used or disclosed without the written consent of LYSAGHT MARKETING SDN BHD. CO. NO.: 102382-M				DIMENSIONS IN mm UNLESS STATED	SHEET SIZE A4
REV	DETAILS	BY	CHD	DATE											